

COMPACT FUSION

OPERATOR'S MANUAL

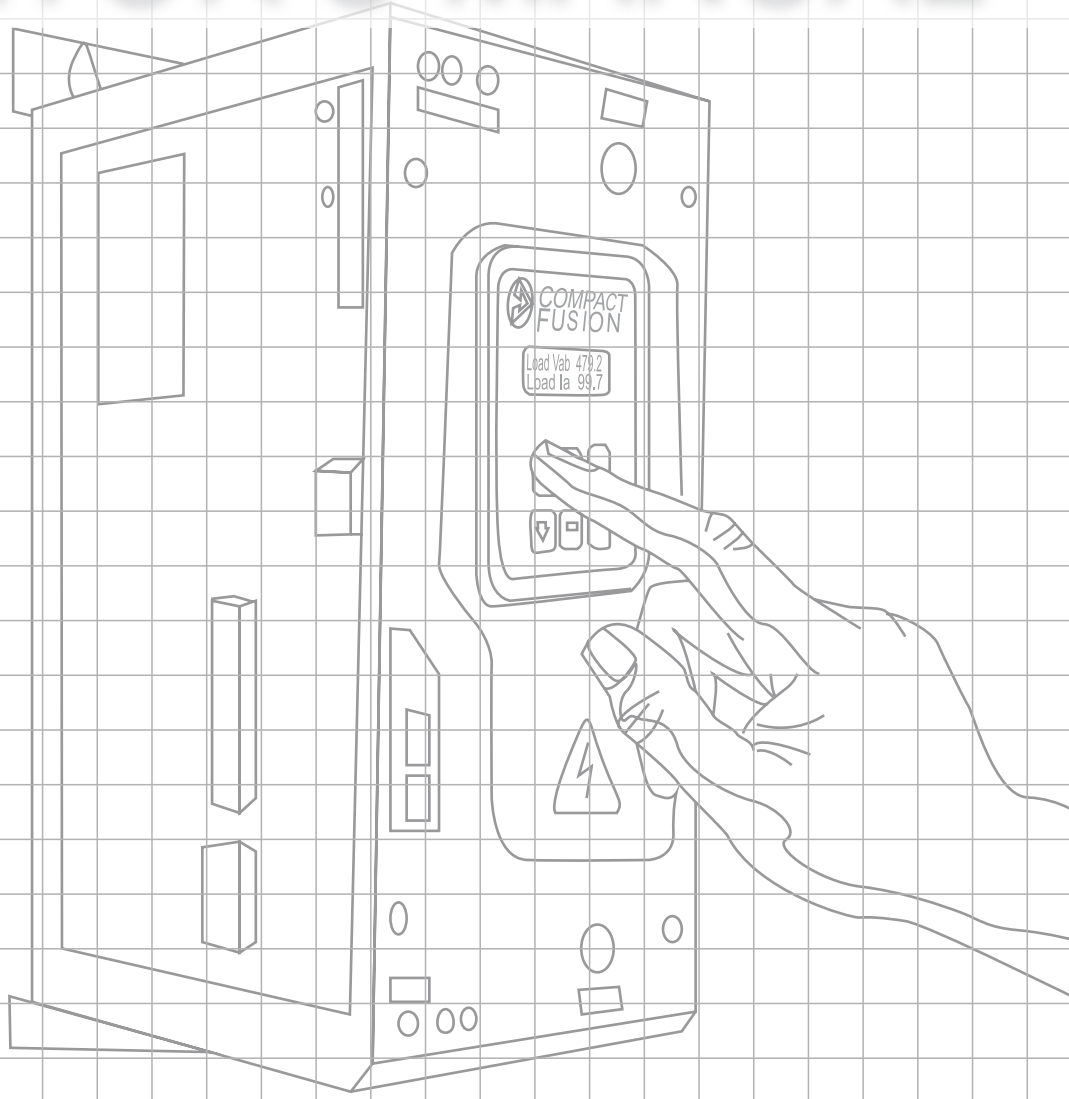
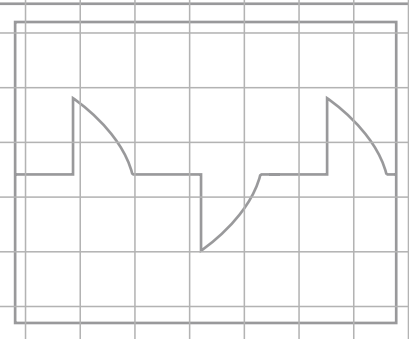
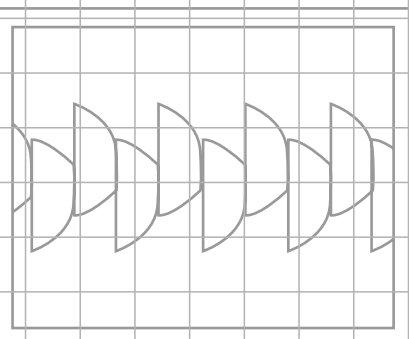
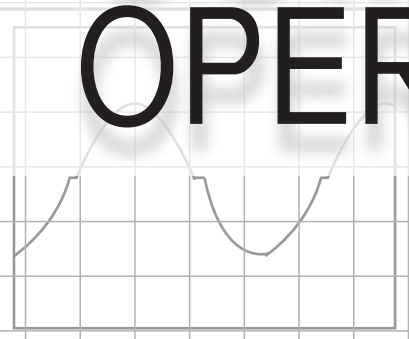

CONTROL CONCEPTS, INC. 2 YEAR LIMITED WARRANTY

CONTROL CONCEPTS, INC. warrants that the products delivered will be as described in the sales order or contract.

CONTROL CONCEPTS, INC. warrants to the original user that CONTROL CONCEPTS, INC. products will be free from defects in materials and workmanship for a period of two (2) years after the date CONTROL CONCEPTS, INC. ships such products.

If any CONTROL CONCEPTS, INC. product is found to be defective in material or workmanship during the applicable warranty period, CONTROL CONCEPTS, INC.'s entire liability, and purchasers sole and exclusive remedy, shall be the repair or replacement of the defective product at CONTROL CONCEPTS, INC.'s election. CONTROL CONCEPTS, INC. shall not be liable for any costs or expenses, whether direct or indirect, associated with the installation, removal or re-installation of any defective product. All shipping and freight costs are the responsibility of the customer. CONTROL CONCEPTS, INC.'s limited warranty shall not be effective or actionable unless there is compliance with all installation and operating instructions furnished by CONTROL CONCEPTS, INC., or if the products have been modified or altered without the written consent of CONTROL CONCEPTS, INC., or if such products have been subject to accident, misuse, mishandling, tampering, negligence or improper maintenance. Any warranty claim must be submitted to CONTROL CONCEPTS, INC. in writing within the stated warranty period.

CONTROL CONCEPTS, INC.'s limited warranty is made in lieu of, and CONTROL CONCEPTS, INC. disclaims all other warranties, whether expressed or implied, including but not limited to any IMPLIED WARRANTY OF MERCHANTABILITY, ANY IMPLIED WARRANTY OF FITNESS FOR A PARTICULAR PURPOSE, any implied warranty arising out of a course of dealing or of performance, custom or usage of trade.

CONTROL CONCEPTS, INC. SHALL NOT, UNDER ANY CIRCUMSTANCES BE LIABLE FOR ANY DIRECT, INDIRECT, INCIDENTAL, SPECIAL OR CONSEQUENTIAL DAMAGES (INCLUDING, BUT NOT LIMITED TO, LOSS OF PROFITS, REVENUE OR BUSINESS) OR DAMAGE OR INJURY TO PERSONS OR PROPERTY IN ANY WAY RELATED TO THE MANUFACTURE OR THE USE OF ITS PRODUCTS. The exclusion applies regardless of whether such damages are sought based on breach of warranty, breach of contract, negligence, strict in tort, or any other legal theory, even if CONTROL CONCEPTS, INC. has notice of the possibility of such damages.

By purchasing CONTROL CONCEPTS, INC.'s products, the purchaser agrees to the terms and conditions of this limited warranty.

WARNING: The Control Concepts, Inc. power controllers use power thyristors to switch voltage to the connected load. Line voltage must be assumed at the output terminals at all times, even when the control signal has been removed and the load voltage appears to be off. It has been mandated by the National Electrical Code and the Occupational Safety and Health Act of 1970 that a physical disconnect be opened ahead of all remotely actuated controls before performing any maintenance work on the controller or its connected load.

PROPRIETARY DATA

© Copyright 2010, Control Concepts, Inc. Chanhassen, MN 55317

The information and design disclosed herein are the property of Control Concepts, Inc. and may not be used, reproduced or disclosed in any form except as granted in writing by:

CONTROL CONCEPTS, INC
18760 LAKE DRIVE EAST
CHANHASSEN, MN 55317
PHONE: (952) 474-6200
TOLL FREE: (800) 765-2799
FAX: (952) 474-6070
www.cciipower.com

TABLE OF CONTENTS

DECLARATION OF CONFORMITY	ii
CERTIFICATE OF COMPLIANCE	iv
1. OVERVIEW	1
1.1 Certifications / Markings	2
1.2 Points of Interest.....	2
1.3 Model Options & Description	3
1.4 Load Types	3
2. INDICATOR LEDs	4
3. COMMUNICATIONS	5
3.1 USB Interface	5
3.2 Factory Industrial Communications Interface	5
3.2.1 Modbus RTU [RS-485] Interface (Optional).....	5
3.2.2 Modbus TCP [Ethernet] Interface (Optional).....	5
3.2.3 DeviceNet Interface (Optional).....	5
3.2.4 PROFINET Interface (Optional)	5
3.2.5 EtherNet/IP Interface (Optional).....	5
4. OPERATION MODES	6
4.1 Phase Angle.....	6
4.2 Zero Cross	7
4.2.1 TRANS-GUARD™	7
4.2.2 SYNC-GUARD™	8
4.3 Zero Cross Transformer Mode (ZCT)	9
4.4 Burst	9
5. START-UP PROCEDURE	10
6. DISPLAY / KEY PAD OPERATION	11
6.1 Screen Lists	11
6.2 Parameter Lock	11
7. BASIC OPERATION & SETTINGS	12
7.1 Control Mode [SP 3] [SP 23] [SP 43] [SP 63]	12
7.2 Feedback Type [SP 1] [SP 21] [SP 41] [SP 61]	12
7.3 Firing Mode [SP 2] [SP 22] [SP 42] [SP 62].....	13
7.4 Full Scale Voltage [SP 8] [SP 28] [SP 48] [SP 68].....	13
7.5 Full Scale Current [SP 9] [SP 29] [SP 49] [SP 69].....	13
7.6 Full Scale Power [SP 10] [SP 30] [SP 50] [SP 70].....	13
7.3 Setpoints.....	14
7.3.1 Digital Setpoints	14
7.3.2 Analog Setpoints	14
7.3.3 External Feedback	15
7.3.4 Digital System Command [SP 129].....	15

7.4 Limits & Trip Settings	16
7.4.1 Voltage Limit [SP 11] [SP 31] [SP 51] [SP 71].....	16
7.4.2 Current Limit [SP 12] [SP 32] [SP 52] [SP 72]	16
7.4.3 Power Limit [SP 15] [SP 35] [SP 55] [SP 77]	16
7.4.4 Current Trip [SP 14] [SP 34] [SP 54] [SP 74].....	16
8. TROUBLESHOOTING	17
8.1 Warning Alarms	19
8.1.1 Voltage Limit	19
8.1.2 Current Limit	19
8.1.3 Power Limit	19
8.1.4 Heat Sink Temp.....	19
8.1.5 Shorted SCR.....	19
8.1.6 Low Output.....	20
8.2 Inhibit Alarms	20
8.2.1 AC Line Sync PLL.....	20
8.2.2 Current Trip.....	20
8.2.3 Line Loss.....	20
8.2.4 Heat Sink Temp.....	20
8.2.5 Fuse Blown	21
8.2.6 Other Non-Typical Alarms.....	21
8.3 Heatsink Warning/Inhibit Alarm Temperatures.....	21
8.3.1 Hero Mode	21
APPENDIX A - SPECIFICATIONS	22
APPENDIX B: MODEL NUMBER IDENTIFICATION	24
APPENDIX C: QUICK START GUIDE.....	25



Listed 3L32 - Industrial Control Equipment
100kA Short Circuit Current Rating
File Number E136219



EN60947-4-3
IP 20
See CE Declaration of Conformity



Part 15 Subpart B
Class A Device



See RoHS Certificate of Compliance

DECLARATION OF CONFORMITY

FUSION CF Series SCR Power Controller

Control Concepts, Inc.
18760 Lake Drive East
Chanhassen, MN 55317 USA



Declares that the following product:

Designation: FUSION CF Series Power Controller
Model Numbers: Model CF followed by ZC, PA, followed by 1, 2 or 3, followed by 1 through 9 or A through E followed by number or letter, may be followed by numbers and/or letters, may be followed by numbers and/or letters, may be followed by numbers and/or letters.
Classification: Solid State Power Controller, Class I, Pollution Degree II
Rated Voltage: 24 - 600 Vac
Rated Frequency: 45 - 65 Hz

Meets the essential requirements of the following European Union Directive(s) using the relevant section(s) of the normalized standards and related documents shown:

EN 60947-4-3: 2000 Low-voltage switchgear and controlgear

EMC Directive 2004/108/EC

-EN 61000-6-2: 2005

-EN61000-4-2: 1995 + Amendments A1:1998 + A2: 2001

-EN61000-4-3: 2006

-EN61000-4-4: 2004 + Corrigendum 2004

-EN61000-4-5: 2006

-EN61000-4-6: 2007

-EN61000-4-8: 1993 + Amendment A1: 2001

-EN61000-4-11 Second Edition: 2004

-EN 61000-6-4: 2007

ESD Immunity

Radiated Immunity

EFT / Burst Immunity

Surge Immunity

Conducted Immunity

Magnetic Field Immunity

Voltage Dips & Interruptions

Conducted & Radiated Emissions

Note 1: All power terminals must be populated as to keep the controller touch safe to comply with EN 60947-4-3.

Note 2: Controller must be mounted in a shielded enclosure to comply with EMC Directive 2004/108/EC.

Note 3: Controller must have appropriate line and control power filter to comply with EN61000-6-2.

Third party conformance testing conducted by TÜV America.

TÜV SÜD America Inc.
Suite 104
1774 Old Highway 8 NW
New Brighton, MN 55112-1891

Name of Authorized Representative: Cory Watkins
Title of Authorized Representative: President

Place of Issue: Chanhassen, Minnesota, USA
Date of Issue: December 2010

Signature of Authorized Representative

12 | 20 | 2010

Date

External EMI filters must be used in conjunction with the FUSION series power controllers to maintain CE immunity* approval. The following filters were used during the immunity testing.

Universal input power:
Schaffner filter
P/N: FN 2030-3-06

Line input power:
Schaffner filter
P/N: FN 3270H-35-33

The Schaffner filter for universal input power, or it's equivalent, may be used as listed above. The line input power filter however, will need to be sized accordingly for your load. Please contact Schaffner EMC Inc. for help finding the appropriate filter.

Schaffner EMC Inc.
52 Mayfield Avenue | Edison, New Jersey 08837 / USA
T 1-800-367-5566 | T 732-225-9533 | F 732-225-4789
usasales@schaffner.com | <http://www.schaffner.com/us>

*No filtering is required for emissions.

Wire filters as shown below:

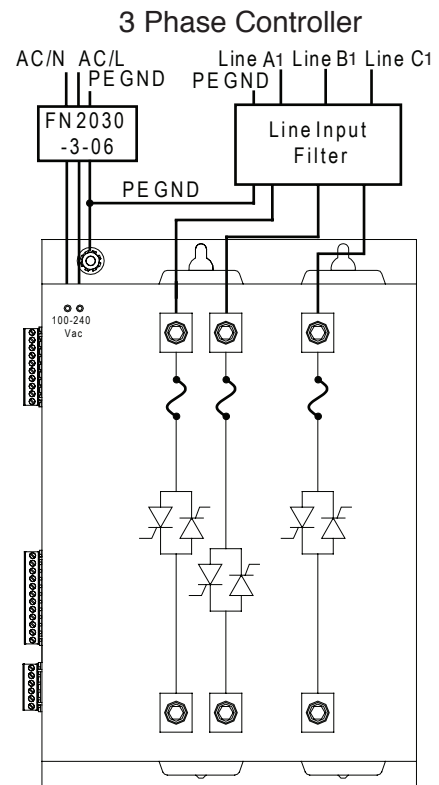
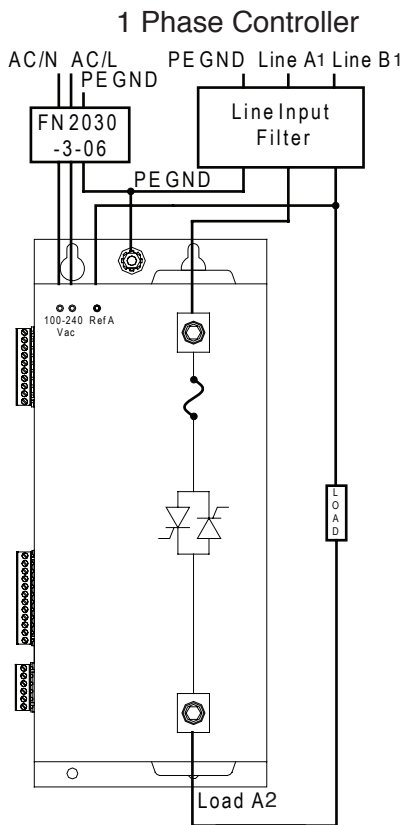

Other wire diagrams are available, for models not listed here, by contacting Control Concepts, Inc.

ATTENTION

This product has been designed for class A equipment. Use of this product in domestic environments may cause radio interference, in which case the user may be required to employ additional mitigation methods.

NOTICE

This product has been designed for environment A. Use of this product in environment B may cause unwanted electromagnetic disturbances, in which case the user may be required to take adequate mitigation measures.

PB-FREE/REDUCTION OF HAZARDOUS SUBSTANCE (RoHS)
CERTIFICATE OF COMPLIANCE



This document certifies that Control Concepts, Inc's products listed in the table are fully RoHS compliant as of Nov 13, 2009 in accordance with EU RoHS Directive 2002/95/EC. The products listed in the table have been identified as RoHS compliant do not exceed the maximum limit for the six substances: Lead, Mercury, Cadmium, Hexavalent chromium, Polybrominated biphenyls and Polybrominated diphenyl ether.

PRODUCT FAMILY	PART NUMBERS	DATE ADDED
FUSION	FUSION-□□-□-□□□□-□-□□□□-□□□□	11/13/2009
FUSION CF	CF-□□-□-□□□□-□-□□□□-□□□□	12/20/2010

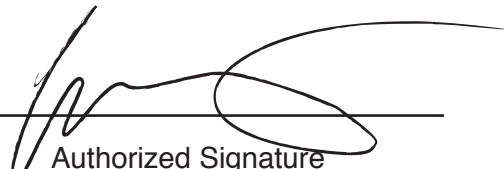

 Authorized Signature
 Cory Watkins, President

12 | 20 | 2010

 Date Last Updated

CONTROL CONCEPTS, INC.
 18760 LAKE DRIVE EAST
 CHANHASSEN, MN 55317
 (952) 474-6200
 1-800-765-2799
 FAX (952) 474-6070
 www.ccipower.com

1. OVERVIEW

The Compact FUSION series controller is a modular digital controller capable of single phase or three phase operation. The modular design allows up to four independent zones of control within one footprint-saving package.

Compact FUSION is nearly identical to its predecessor FUSION, but with a narrower footprint, onboard branch-rated protection fusing (Class T), and a blown fuse indicator for each line. Optional pass through fusing allows a line to pass through the single phase controller to fuse the return leg of the load.

Loads can be controlled in phase-angle, zero-cross, or burst modes for operation of resistive or transformer connected loads. Output is controlled linearly with respect to command signal and can be set to the average or RMS value of the voltage or current, as well as true instantaneous power or external feedback.

Compact FUSION controllers are available in current ratings from 10 - 160 amps AC. Auto-ranging voltage circuitry enables mains supply voltage from 24-600 VAC, (45-65 Hz) eliminating the need for hardware jumpers or stocking multiple controllers for international voltages. A separate power source supplies the control electronics and maintains critical communications to your control system when the mains are absent.

An integrated display and on-board diagnostics make operation and trouble shooting simple. Limits, set-points, and alarm conditions can be easily viewed and customized. A plug-n-play USB interface and free FUSION Control Panel software for the PC further simplifies installing and configuring the controller to your application. OEMs, for example, can duplicate controller settings by simply loading a configuration file saved from a previous unit.

Parameters can be easily viewed and controlled through the onboard display. For additional convenience, the display can also be remotely mounted on an electrical enclosure door.

Setpoints can be controlled through the standard analog or optional Fieldbus interface. The factory-configured analog setpoint signal ranges are 0 - 5 Vdc and 4 - 20 mA, both of which are field scalable from 0 - 10 Vdc or 0 - 20 mA.

The Fieldbus interface options include Modbus RTU (RS-485), Modbus TCP (Ethernet), DeviceNet™, ProfiNet (Ethernet) and Ethernet/IP. These interface options can be used to communicate with a PLC or factory control system. For multi zone controllers consisting of 3 or 4 zones, a Fieldbus interface is required.

1.1 Certifications / Markings

Controllers meet UL, CE and RoHS standards for safety, emissions and environment.

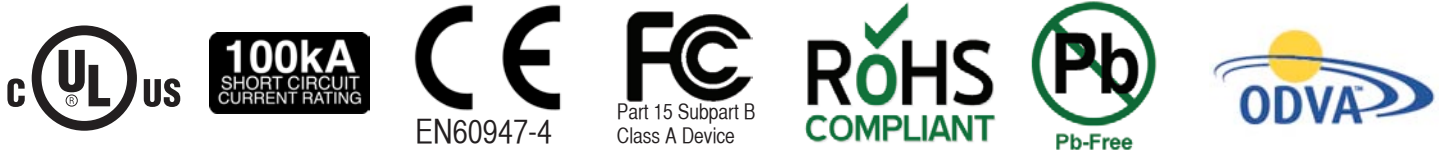

In addition to certification markings, the controllers will also be marked with:

Model Number
Serial Number
Voltage Range (24 - 600 Vac)
Current Size

1 Phase or 3 Phase
Frequency (45 - 65 Hz)
Control Concepts contact information
Torque information on Line / Load connections

1.2 Points of Interest

A. BASE PLATE WITH GROUND STUD

Metal mounting plate to ground the controller.

B. UNIVERSAL INPUT POWER

Operates circuitry and on-board fans when present. Allows users to configure controller without line power.

C. OPTIONAL AUX I/O CARD

(P3) Provides additional features. Has two digital inputs, two digital outputs, and two analog outputs (retransmits)

D. DISPLAY, KEYPAD, & OPT. REMOTE DISPLAY

Shows parameter name with information such as setpoints, limit settings, monitor features, alarms, and more. The display can be easily mounted outside an electrical panel for efficiency.

E. COMMAND CONNECTIONS

(P1) Analog inputs, setpoint select, run/reset, SYNC-GUARD™ feature.

F. INDICATOR LEDs, USB PORT, & DIGITAL COMMUNICATIONS

Streamlines controller setup, configuration, diagnostics, and troubleshooting. Digital communication options include DeviceNet, Modbus RTU or TCP, EtherNet/IP, and PROFINET.

G. RELAY CONNECTIONS

(P2) Alarms can be mapped to two internal relays for external triggering.

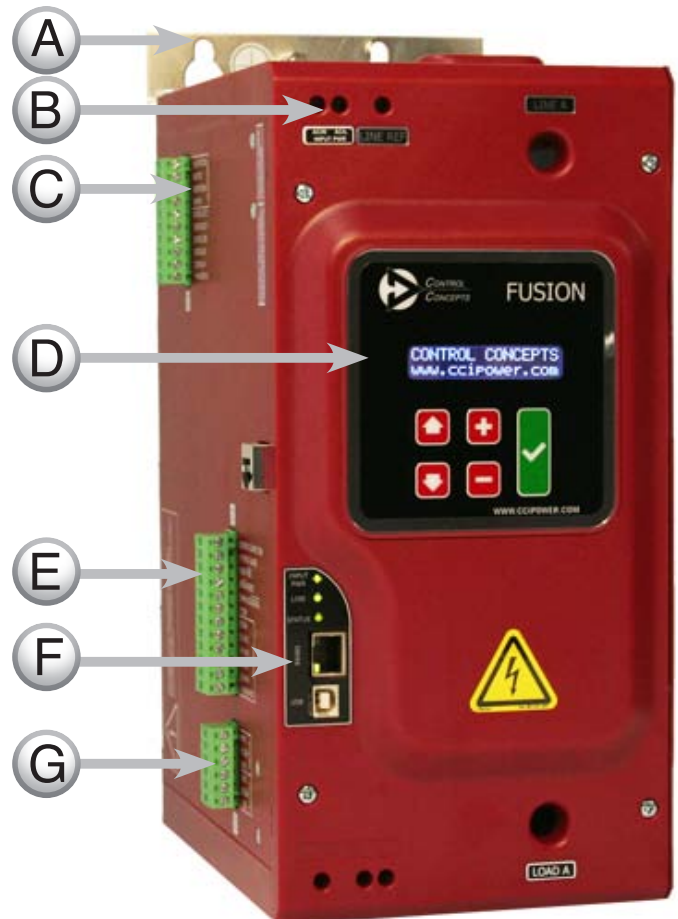

1.3 Model Options & Description

Single Phase AC

The single phase AC power controller is a phase angle or zero cross fired controller. It linearly controls, with respect to the setpoint, the AC voltage, current or true power applied to an electrical load. Control is achieved by means of a pair of inverse parallel SCR's.

Three Phase - Two Leg

The three phase two leg AC power controller is a zero cross fired controller. It linearly controls, with respect to the setpoint, the AC voltage, current or true power applied to an electrical load. Control is achieved by two pairs of inverse parallel SCR's.

Three Phase - Three Leg

The three phase three leg AC power controller is a phase angle or zero cross fired controller. It linearly controls, with respect to the setpoint, the AC voltage, current or true power applied to an electrical load. Control is achieved by three pairs of inverse parallel SCR's.

1.4 Load Types

Loads / Applications

1. Constant Resistive Loads (Nickel Chromium)
2. Variable Resistive Loads
 - a. Silicon Carbide
 - b. Molybdenum Disilicide
 - c. Graphite
 - d. Tungsten Lamps
3. Transformer Coupled Loads (see Transformers section)
4. Inductive (not intended for motor applications)
5. Gas Discharge
 - a. Ultra Violet
6. Electron Beam
7. Crystal Growing and Processing

Transformers

Scott-T & Wye transformers: Excessive voltage transients can occur when operating Scott-T transformers with an open or unloaded secondary. It is recommended that Scott-T transformer be limited to a maximum of 480 Volts.



NOTE: It is recommended that a Delta to 4-Wye transformer be used to power a 4-wire Wye load. Delta to 3-wire Wye transformers are acceptable, but Wye to Wye transformers are not suited for use between the controller and load due to possible transient conditions.

2. INDICATOR LEDs

INPUT PWR LED turns green when the Universal Input has been connected and power is applied.
LINE LED turns green when the Lines have been connected and power is applied (input power is also required).

STATUS LED turns green when the controller is in a run state. If the LED is flashing orange, the controller has a Warning Alarm. If the LED is red, there is an Inhibit Alarm. Note: The LED will be off if there are no alarms but the controller is not in a “Run” state.



NOTE: Line reference is required for single phase, three phase 2 leg, and three phase 4 wye controllers only.



Standard



Modbus RTU
(RS 485)



Modbus TCP
(Ethernet)
EtherNet/IP
PROFINET



DeviceNet

3. COMMUNICATIONS

3.1 USB Interface

A USB interface is standard on all controllers. Included with each controller is a software package titled 'FUSION Control Panel'. This allows the user to connect to the controller using a computer and USB cable. See the FUSION Control Panel manual for details on how to use the software.

Control Concepts stocks 15 foot USB cables for customers to purchase (P/N: 0058004-0000-15).

3.2 Factory Industrial Communications Interface

Modbus communication is one of the most commonly used communication types in an industrial manufacturing environment. It allows communication between many devices (up to 247) on the same network.

Control Concepts offers a Modbus Developers software kit that allows users to write their own protocols. There is a hardware kit available for purchase (P/N: SMAFUSION-MDK) that includes a Modbus converter, splitter and terminating plug. This will allow controllers to be "Daisy Chained" together and controlled from a single interface.

Control Concepts highly recommends the use of shielded wiring and offers a variety of lengths to purchase.



Note: Only one type of interface is available per unit. For example a controller with Modbus RTU cannot also have Modbus TCP.

3.2.1 Modbus RTU [RS-485] Interface (Optional)

See Modbus manual for details

3.2.2 Modbus TCP [Ethernet] Interface (Optional)

See Modbus manual for details

3.2.3 DeviceNet Interface (Optional)

See DeviceNet manual for details

3.2.4 PROFINET Interface (Optional)

See ProfiNet manual for details.

3.2.5 EtherNet/IP Interface (Optional)

See EtherNet/IP manual for details.

4. OPERATION MODES

Knowing the application and the type of load you are trying to control is critical for choosing the right mode of operation. The Compact FUSION Series power controllers are capable of Phase Angle and Zero Cross operations. The following sections will describe each type of operation and will show the expected output.



Note: For proper load operation, correct wiring is critical. See the “Wiring” section of the Installation & Maintenance Manual.

4.1 Phase Angle

In phase-angle control, each SCR of the back-to-back pair is turned on for a variable portion of the half-cycle that it conducts. Power is regulated by advancing or delaying the point at which the SCR is turned ON within each half cycle. Light dimmers are an example of phase-angle control.

Phase-angle control provides a very fine resolution of power and is used to control fast responding loads such as tungsten-filament lamps or loads in which the resistance changes as a function of temperature.

Single Phase Operation

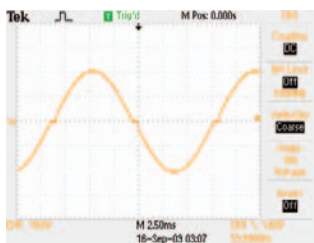

100% Load Power

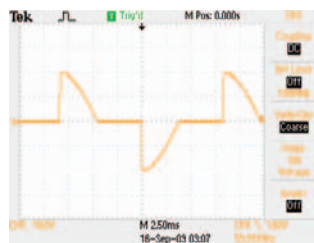

50% Load Power

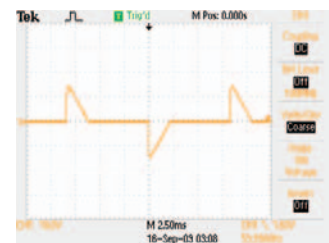

25% Load Power

Three Phase Operation

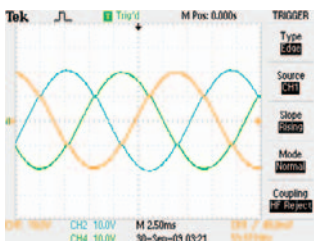

100% Load Power

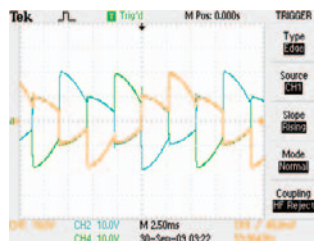

50% Load Power

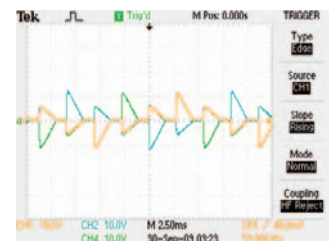

25% Load Power

4.2 Zero Cross

In zero-cross control, load power is turned ON and OFF only when instantaneous value of the sinusoidal waveform is zero. Load power is controlled by switching the SCRs “ON” for a number of complete electrical half-cycles, and then “OFF” for a number of complete electrical half-cycles.

The wave form in the top left shows the 1 phase AC waveform into the controller. This would also be the representation of the output with the command at 100%. The rest of the waveforms show the “ON” and “OFF” cycles of the output at various setpoints.

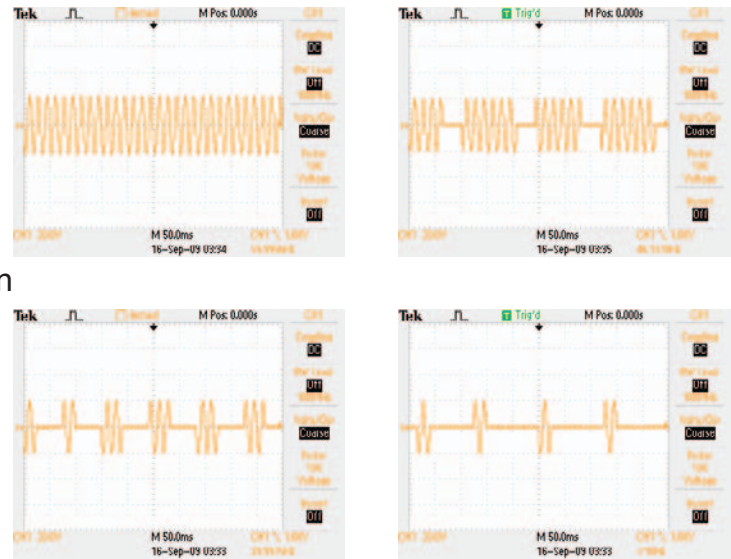

The tabulation on the right shows the sequence of “ON” and “OFF” electrical half-cycles that are applied to the load to achieve the percentage of load power indicated. The percentage of load power is equal to; the ratio of the number of electrical half-cycles that power is applied, to the total number of electrical half-cycles. From the tabulation, it can be seen that power is applied for 16 out of 32 electrical half-cycles to achieve 50% load power and that power is applied for 136 out of 160 electrical half-cycles to obtain 85% power. When operating with a 60 Hz supply, the sequence of ON and OFF cycles repeats 0.266 seconds on 50% and every 1.33 seconds at 85% power.

LOAD POWER TIMING				
10%	25%	50%	75%	85%
5 ON	5 ON	9 ON	17 ON	23 ON
46 OFF	14 OFF	8 OFF	6 OFF	4 OFF
5 ON	5 ON	7 ON	19 ON	23 ON
44 OFF	16 OFF	8 OFF	6 OFF	4 OFF
				23 ON
				4 OFF
				23 ON
				4 OFF
				23 ON
				4 OFF
				21 ON
				4 OFF



Note: Even though it takes 1.33 seconds to obtain precisely 85% power, the load power during the 23 ON and 4 OFF cycles is 23/27 or 85.185% power and that this cycle is repeated every 0.225 seconds.

4.2.1 TRANS-GUARD™

The TRANS-GUARD™ feature eliminates a DC component that can exist with zero-cross operation. Elimination of this DC component prevents saturation and over heating of the upstream supply transformers. TRANS-GUARD™ is a standard feature on all zero-cross controllers. There is no set-up required.

4.2.2 SYNC-GUARD™

The SYNC-GUARD™ feature reduces the possibility of synchronous operation of two or more zero cross controllers. This feature does not alter the power applied to the load, but adjusts the time when power is applied in such a manner as to reduce the possibility of two or more controllers being ON and OFF in unison.

SYNC-GUARD™ is useful whenever there are two or more power controllers connected to the same power source with a zero-cross firing mode selected. The SYNC-GUARD™ feature can significantly reduce the peak current required from a source that is connected to multiple power controllers while all are zero cross firing.

Zero cross firing is an ON-OFF type of control where the desired voltage, current, or power is delivered to the load by varying the controller's ON-OFF duty cycle. With zero cross firing, when the controller's output is ON, full supply voltage and current are provided to the load.

Without SYNC-GUARD™, multiple zero cross firing controllers could potentially be ON and OFF all at the same time. This would require heavy current to be drawn from the source while the controllers are all ON and no current when they are all OFF. The SYNC-GUARD™ feature works to reduce the peak current draw required from the source over time by causing each controller to attempt to find a time to turn ON when fewer, or no other, controllers are firing.

Limitations

As stated before: the SYNC-GUARD™ feature works to reduce the peak current draw required from the source for multiple controllers over time. However, each controller cannot predict when another controller is going to fire. Therefore the probability of multiple controllers firing at the same time exists even when using the SYNC-GUARD™ feature. The probability of this happening is highest when many controllers transition into the RUN state, and therefore turn ON at the same time. It is recommended that no more than 10 controllers be linked together with SYNC-GUARD™.

The figures below show the total current as a function of time for three controllers, with, and without SYNC-GUARD™ and various load powers. When using the SYNC-GUARD™ feature, the current command signals must be isolated from each other. To set up the SYNC-GUARD™ feature, see the Installation manual.

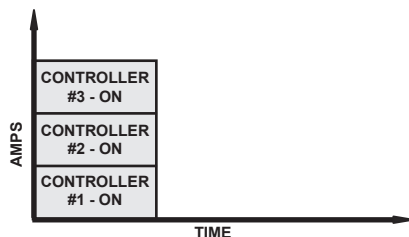

Three controllers providing 33.3% power each, operating synchronously without SYNC-GUARD™

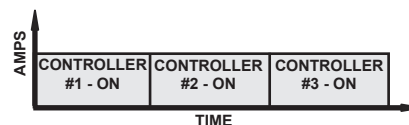

Three controllers providing 33.3% power each, with SYNC-GUARD™

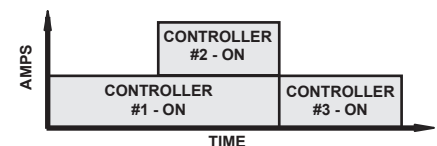

Three controllers with SYNC-GUARD™, two providing 33.3% power & one providing 66.6% power.

To set up SYNC-GUARD™ feature, see the Installation & Maintenance manual.

4.3 Zero Cross Transformer Mode (ZCT)

This is a Control Concepts proprietary algorithm that uses hybrid control to avoid the excessive inrush currents that can occur when firing into inductive or variable resistive loads.

In this firing mode the (on-off) duty cycle is adjusted to obtain the desired amount of power to the load. The “ON” portion of the output begins with a set number of cycles that increase to full conduction, remain at full conduction for a number of cycles, and then turn off. This pattern restarts with each subsequent duty cycle.

When utilizing the “Zero Cross Transformer” (ZCT) firing mode, the Power Factor measured by the controller is typically 0.90 with a setpoint that is greater than or equal to 50%. When the setpoint is less than 50% the controller will maintain a measured Power Factor of approximately 0.70.

Current Limit is enabled during the “phase-up” section of each “ON” portion of the duty cycle. A Power Factor of 0.90 (Setpoint > 50%), or 0.70 (Setpoint < 50%), may not be able to be achieved if the controller was current limiting the output to the load during the phase-up time.

Set-up

After connecting the FUSION controller to the FUSION Control Panel Software, click on the Zone 1 tab. Set the Firing_Mode_Zone_1 to ZeroCross_PhaseAngleStart. Set the Phase_ZC_Switch_Cycles_Zone_1 to the desired number of cycles the controller will use to ramp up to full conduction. This parameter is adjustable from 5 to 20 cycles (default is 12 cycles). If the controller is firing into a transformer, the value entered should be set high enough so that the transformer does not saturate during the start section of the “ON” portion of the duty-cycle.

Transformer Selection

A transformer of at least 1.3 Tesla (13000 Gauss) is preferred for best performance, up to 1.5 Tesla (15000 Gauss) is permissible.

4.4 Burst

Burst mode operates very similar to ZCT Mode. The difference is the first half cycle is fired at a user specified angle.

This type of hybrid control can consequently be used to control the primary of a transformer with transformer coupled loads by avoiding the excessive inrush currents that can occur with magnetizing inductance of the transformer (prevents transformer saturation). The power factor is improved over standard phase angle operation into a transformer.

5. START-UP PROCEDURE

Before applying power to the controller, check that all connections are correct and tightened to the proper torque value. Make sure the controller is in a stop state (not run) via pin 9 of the P1 connector.



1. Apply the universal input power.

Expected Response:

- Display will illuminate and scroll initial start-up screen.
- *Display will read "INHIBIT ALARM" with LINE LOSS and AC LINE SYNC PLL alarms scrolling.

2. Verify proper system and zone settings

- Control mode set for desired operation (Phase Angle, Zero Cross, etc).
- Full scale settings are correct.
- Limit settings are correct.
- If a 3 phase controller, verify 3 phase load config is set for correct load type (Delta or 3 Wire Wye, Inside Delta or 4 Wire Wye).

3. Apply the line power. Line LED will turn on to indicate power.



4. Place the controller in Run mode by closing Pin 9 of the P1 connector.

- If the status LED does not change to green when this is closed the Digital Enable check box is not checked.
- Open the FUSION Control panel software and check the zone "Enable" button in the Dashboard section.

5. When all indicator LEDs are green, apply a command signal. The output of the controller will respond linearly to the command signal.



* When the line power is applied these two alarms will go away.

NOTE: If the status LED is red or flashing orange the display will read the inhibit or warning alarm that is causing the alarm. See the troubleshooting section in this manual for details on alarms.

6. DISPLAY / KEY PAD OPERATION

After applying universal input power, the user can now edit parameters via the display or the FUSION Control Panel Software.

Auto Scroll

The 5 button display has an auto scroll and manual scroll display list.

Pictured right are examples of how screens will appear.

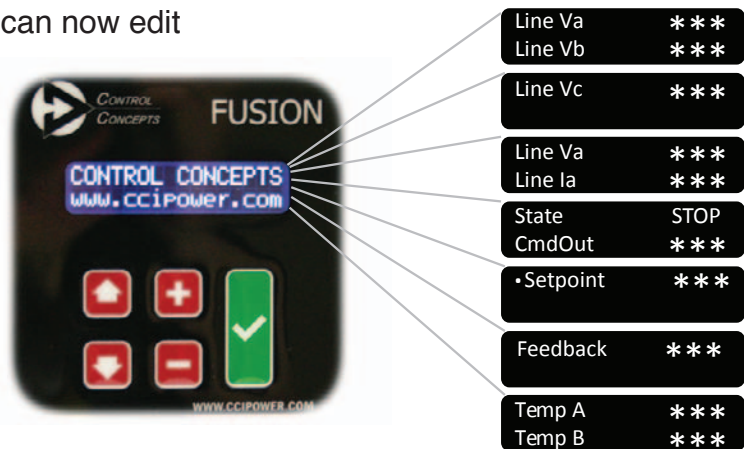

Manual Scroll

The controller will automatically start in auto scroll mode. The screen will change every few seconds. Press the arrow keys to access the manual scroll display list.



The up and down buttons will also scroll through different screens. To return to auto scroll, press and hold either button for a minimum of two seconds. If the display idles for ten minutes in manual scroll, it will automatically return to auto scroll.



Changing Value

On setable parameters there will be a dot in front of the parameter name. To adjust the value, press the green button.

The dot will change to an arrow. See examples, right.

Press the Plus and Minus buttons to adjust the value up or down.

After the desired value is reached, press the green button to accept the changes. The screen should appear as before with the adjusted value.

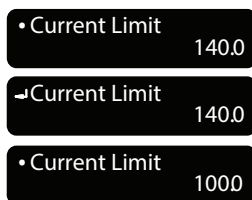

Note: If the parameter entry is left unchanged, or the accept button is not pressed, within 20 seconds the parameter will abort and return to the original value.

6.1 Screen Lists

Each controller is shipped with a customizable screen list that pertains to the hardware configuration of the controller. The default lists will show things such as line/load voltages, load currents and heatsink temperatures. If the controller is equipped with a communications card the default list will also show specific parameters pertaining to the communications settings.

The screen list can be customized by connecting to the FUSION Control Panel software. Within the software any combination of screens can be programmed onto the screen (limit 50 screens).

6.2 Parameter Lock

A parameter lock can be setup to prevent anyone from changing parameter values using the display keypad. See direction on how to set this up in the Display Control section of the FUSION Control Panel software manual.

7. BASIC OPERATION & SETTINGS

For single phase controllers multiple zones may be present. Each zone of the controller has its own list of parameters to configure. The following parameters will be followed by a list of numbers contained in square brackets. The numbers will correspond to the zone it pertains to. For example Control Mode [SP 3] [SP 23] [SP 43] [SP 63], SP 3 is for Zone 1, SP 23 is for Zone 2, SP 43 is for Zone 3 and SP 63 is for Zone 4.

If only one zone exists only configure Zone 1 parameters and ignore all other zones.

7.1 Control Mode [SP 3] [SP 23] [SP 43] [SP 63]

By default this is set to Closed Loop.

Closed Loop – the output is adjusted so that the feedback equals the setpoint.

Open Loop – the output percentage is directly proportional to the setpoint and the feedback is not used.

7.2 Feedback Type [SP 1] [SP 21] [SP 41] [SP 61]

The Feedback type determines how the control loop feedback works. By default this is set to *RMS Voltage*.

RMS Voltage – Use RMS Voltage as the control loop feedback.

AVG Voltage – Use average voltage as the control loop feedback.

RMS Current – Use RMS current as the control loop feedback.

AVG Current – Use average current as the control loop feedback.

Power – Use real power as the control loop feedback

External – Use an external transducer that provides the feedback signal.

Apparent Power – Use apparent power as the control loop feedback.

Here are the calculations on how the feedback is measured:

RMS Voltage

$$V_{rms} = \sqrt{\frac{\sum_{i=1}^n (Vi)^2}{n}} = 0.707 V_{pk}$$

RMS Current

$$I_{rms} = \sqrt{\frac{\sum_{i=1}^n (Ii)^2}{n}} = 0.707 I_{pk}$$

Power

The output is adjusted via the real Power.

$$\text{Real Power} = \frac{\sum_{i=1}^n (Vi * Ii)}{n}$$

AVG Voltage

$$V_{avg} = 1.11 \frac{\sum_{i=1}^n |Vi|}{n} = 0.707 V_{pk}$$

AVG Current

$$I_{avg} = 1.11 \frac{\sum_{i=1}^n |Ii|}{n} = 0.707 I_{pk}$$

$$\text{Apparent Power} = V_{rms} * I_{rms}$$

$$\text{Power Factor} = \frac{\text{Real Power}}{\text{Apparent Power}}$$

V_{pk} = Peak Voltage

Vi = Instantaneous Voltage sample

n = number of samples in 1 AC line cycle

I_{pk} = Peak Current

Ii = Instantaneous Current sample

7.3 Firing Mode [SP 2] [SP 22] [SP 42] [SP 62]

The default setting will be *Zero Cross* or *Phase Angle*, which is determined at the time of ordering. Available settings are *Zero Cross*, *Zero Cross Burst*, *Phase Angle* or *Zero Cross Transformer Mode*.

7.4 Full Scale Voltage [SP 8] [SP 28] [SP 48] [SP 68]

The voltage that will be applied when the load is at full capacity. The closer the full scale voltage is to the actual voltage the more accurate the controller will be. Setting this slightly higher than the actual voltage is common. This should not be set to more than 2X the actual voltage. The factory default value is set to 480 V.

7.5 Full Scale Current [SP 9] [SP 29] [SP 49] [SP 69]

The current when the load is at full capacity. The closer the full scale current is to the actual current, the more accurate the controller will be. Setting this slightly higher than actual current is common. This should not be set to more than 2X the actual current. The default value is set to the frame rating of the controller.

7.6 Full Scale Power [SP 10] [SP 30] [SP 50] [SP 70]

The power when the load is at full capacity. This should not be set to more than 2X the actual power. The default value is calculated from the following:

1 Phase AC	3 Phase AC	
[Full Scale V] x [Full Scale I]	Delta, 3 & 4 Wire Wye	Inside Delta
	[Full Scale V] x [Full Scale I] x $[\sqrt{3}]$	[Full Scale V] x [Full Scale I] x [3]



Note: In the FUSION Control Panel Software there is a “Calculate” button for these equations. This will automatically fill in the full scale power once pressed. It will also automatically set up the limit settings.

7.3 Setpoints

There are four possible setpoints: two digital, two analog. These can be selected by connecting pins 7, 8, and 10 on the P1 command connector. The diagram on the right shows how to access each setpoint with the use of two switches. For wiring analog setpoints see the Installation & Maintenance Manual.

	Switch A	Switch B
Analog Setpoint 1	Open	Open
Analog Setpoint 2	Closed	Open
Digital Setpoint 1	Open	Closed
Digital Setpoint 2	Closed	Closed

7.3.1 Digital Setpoints

There are two digital setpoints available. The digital setpoint can be entered as a percent (0 - 100%) via the display. The setpoints can also be set via the USB, RS-485 or Ethernet interfaces. To enter the digital setpoint via a PC interface, see the FUSION Control Panel software manual.

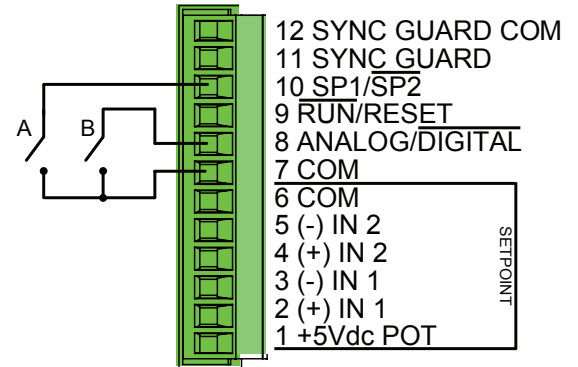

7.3.2 Analog Setpoints

There are two analog inputs on each controller. A single zone controller can select either setpoint 1 or setpoint 2. Single zone controllers have special functionality in that analog setpoint 2 can be used for external feedback. For 2 zone controllers analog setpoint 1 is for zone 1 where setpoint 2 is for zone 2.

The inputs allow a wide array of input scaling for the user. The hardware capabilities are 0 - 10 Vdc for voltage and 0 - 20 mA for current. The factory default setting for SP1 is 4 - 20 mA and SP2 is set for 0 - 5 Vdc.

To make changes to the analog inputs, open the FUSION control panel software and check the “System Tab” button. In the Analog Setpoints section, there are settings for SP1 and SP2. Note: when changing setpoints from one type to another, setpoints are not driven to default values.

Example 1: If a 0 - 5 Vdc command is desired for 0 - 100% output using SP1

Controller Setting

- No connection between Pin 7 & 8 on P1 (a connection here would set the setpoint to be in digital mode)
- Connection between Pin 7 & 9 on P1 (with closed to run logic, this would put the controller in a Run state)
- No connection between Pin 7 & 10 (a connection here makes SP2 the active setpoint)

Software Settings

- Analog SP1 Type set to Voltage
- Analog SP1 Lo Cmd set to 0.00
- Analog SP1 Lo Out set to 0.00%
- Analog SP1 Hi Cmd set to 5.00
- Analog SP1 Hi Out set to 100.00%

Example 2: If a 4 - 20 mA command is desired for 0 - 100% output using SP2

Controller Setting

No connection between Pin 7 & 8 on P1 (a connection here would set the setpoint to be in digital mode)

Connection between Pin 7 & 9 on P1 (with closed to run logic, this would put the controller in a Run state)

Connection between Pin 7 & 10 (makes SP2 the active setpoint)

Software Settings

Analog SP2 Type set to Current

Analog SP2 Lo Cmd set to 4.00

Analog SP2 Lo Out set to 0.00%

Analog SP2 Hi Cmd set to 20.00

Analog SP2 Hi Out set to 100.00%

Example 3: If a 0 - 20 mA command is desired for 30 - 100% output using SP1

Controller Setting

No connection between Pin 7 & 8 on P1 (a connection here would set the setpoint to be in digital mode)

Connection between Pin 7 & 9 on P1 (with closed to run logic, this would put the controller in a Run state)

No connection between Pin 7 & 10 (a connection here makes SP2 the active setpoint)

Software Settings

Analog SP1 Type set to Current

Analog SP1 Lo Cmd set to 0.00

Analog SP1 Lo Out set to 30.00%

Analog SP1 Hi Cmd set to 20.00

Analog SP1 Hi Out set to 100.00%

Note: For example 3 - with the setpoint at 0 mA the controller would be on at 30%. When a setpoint is applied the controller will immediately respond. Similarly at 20 mA it would be on at 100%.

7.3.3 External Feedback

To set up external feedback, connect the Compact FUSION controller to a computer with the FUSION Control Panel software installed. Open the program and click "Connect." Then choose the Zone 1 tab and select "External" from the feedback_type_zone_1 drop-down box.

Click on the System tab, set up the Analog SP2 for the signal type and range being used. The Analog_SP2_function should be set to normal.



NOTE: External Feedback is only available on 1 Zone controllers.



NOTE: For instruction about wiring external feedback, see the FUSION Installation and Maintenance manual.

7.3.4 Digital System Command [SP 129]

The Digital System Command can be used to bypass the functionality of the P1 and P2 connector. It is mainly used when using digital communications. This particular parameter requires configuring multiple other parameters. For more details, see the FUSION Control Panel software manual.

7.4 Limits & Trip Settings

The Limits and Trips are safety features of the FUSION Power Controller. These protect the device from excessive voltage, current and/or power. These cannot be set higher or lower than what is listed in this manual. If these settings need to be set outside of the available ranges contact the factory.

7.4.1 Voltage Limit [SP 11] [SP 31] [SP 51] [SP 71]

Limits the voltage applied to the load. The recommended setting is 105% of the full scale voltage. The default value is set to 630 Volts which is 105% of a 600 VAC frame voltage.

7.4.2 Current Limit [SP 12] [SP 32] [SP 52] [SP 72]

Limits the current applied to the load. The recommended setting is 105% of the full scale current. The default value is set to 105% of frame rating.

7.4.3 Power Limit [SP 15] [SP 35] [SP 55] [SP 77]

Limits the power applied to the load. The controller will continue to operate but will not exceed the power specified in this field. The recommended setting is 105% of the full scale power. The default value is set to 105% of the full scale power.

7.4.4 Current Trip [SP 14] [SP 34] [SP 54] [SP 74]

If the current exceeds the setting in this field the controller will shut down. Current Trip responds faster than the current limit setting. This protects the controller from experiencing surge currents that could damage the controller. This will shut the controller down and display an alarm.

For Phase Angle firing mode, the default value is set to 175% of frame rating.
For Zero Cross firing mode, the default value is set to 350% of frame rating.

8. TROUBLESHOOTING

If a problem is thought to exist, first look at the LEDs and the Display on the lid of the controller. Start with the following order:

1. INPUT PWR LED (green)
2. LINE LED (green)
3. STATUS LED (multi-color)
4. Display (backlight)
5. Display (Alarm message)

Problem: INPUT PWR LED is not on

Possible causes:

- Improper connections / wiring issue
- Universal Input Power has not been turned on
- The Universal Input Power is outside of the operating voltage
- The fuse for the Universal Input Power has opened

Things to do:

- Check the wiring from the source to the controller.
- With a multimeter check the voltage at the source and at the controller. Verify that the voltage is within the operating range (100 – 240 Vac)
- Check accessible fuses. If the internal fuse is believed to have opened, contact Control Concepts for further assistance.

Problem: LINE LED is not on

Possible causes:

- Improper connections / wiring issue
- Line fuse has opened
- Line voltage has not been supplied
- Line voltage is outside of the operating voltage
- Line Reference has not been connected (Select models require a line reference)

Things to do:

- Check the wiring from the source to the controller.
- Verify all terminal connections are tightened on the wire and not on the wire insulation.
- Check accessible fuses.
- With a multimeter check the voltage at the source and at the controller. Verify that the voltage is within the operating range (24 – 600 Vac)

Problem: STATUS LED is not on

Possible causes:

- The controller is not in a “Run State”

Things to do:

- Place the controller into a “Run State” with the P1 connector (pins 7 & 9).
- If this does not work, connect the controller to the FUSION Control Panel software and check to see if the P1 connector is wired correctly. Look for the Command I/O section in the Dashboard. Check to see the status of the Run/Reset pin: Run/Stop Closed (P1 connector pins 7 & 9 are closed) and Run/Stop Open (P1 connector pins 7 & 9 are open)

Problem: STATUS LED is green / no output

Possible causes:

- No command signal
- Open Load
- Load is not connected

Things to do:

- Check that the P1 connector is wired correctly. Connect the controller to the FUSION Control Panel software. Look for the Command I/O section in the Dashboard.
- Check to see what type of setpoint is selected: Analog Set Pt (P1 connector pins 7 & 8 are open) and Digital Set Pt (P1 connector pins 7 & 8 are closed)
- Check to see what which setpoint is selected: Set Point 1 (P1 connector pins 7 & 10 are open) and Set Point 2 (P1 connector pins 7 & 10 are closed)
- Check the wiring from the controller to the load. When applicable check with wiring from the load to the return source.

Problem: STATUS LED is Red or is flashing Orange

Possible causes:

- Alarm is preset

Things to do:

- Check display for what alarm is present.

Problem: Display will not turn on

- Possible causes:
- Display wiring
- Internal fuse

Things to do:

- Check the wiring at the display and at the controller to make sure that the connector is properly seated.
- With a multimeter check the voltage on the P1 connector (pin 1 to pin 6). This should read 5 Vdc +/-0.5 Vdc. Contact Control Concepts for further assistance.

8.1 Warning Alarms

During a warning alarm the STATUS LED will be flashing orange. For all controllers, when a warning alarm is present it is displayed on the display. For multi-zone controllers, to determine which zone has the alarm present, connect to the FUSION Control Panel software.

The Warning Alarms may be mapped to Relay 1 and/or Relay 2. This is done through the FUSION Control Panel software. See the Installation and Maintenance Manual for relay wiring details.

8.1.1 Voltage Limit

*** WARNING ALARM*
VOLTAGE LIMIT**

The controller will not be allowed to exceed the voltage limit setting. The voltage limit setting is recommended to be 105% of the Full Scale Voltage setting.

8.1.2 Current Limit

*** WARNING ALARM*
CURRENT LIMIT**

The controller will not be allowed to exceed the current limit setting. The current limit setting is recommended to be 105% of the Full Scale Current setting.

8.1.3 Power Limit

*** WARNING ALARM*
POWER LIMIT**

The controller will not be allowed to exceed the power limit setting. The power limit setting is recommended to be 105% of the Full Scale Power setting.

8.1.4 Heat Sink Temp

*** WARNING ALARM*
HEAT SINK TEM P**

A heat sink is within 5°C of the maximum temperature rating for the SCR. Check the fans for proper operation or for any possible obstructions in the air flow.

8.1.5 Shorted SCR

*** WARNING ALARM*
SHORTED SCR**

The controller is detecting a shorted SCR.

All controllers have shorted SCR detection. This will detect any shorted SCR in any zone, with any load type, and any phase rotation with the following exception.

Only certain zones can be detected in a three phase Zero Cross or three phase Zero Cross Burst mode controller with a delta or 3-wire wye load. The phase rotation also affects which zone can be detected.

This feature is user-selectable. A user may disable the Shorted SCR alarm in the case of nuisance warnings.

	Phase Rotation 123			Phase Rotation 321		
	Zone			Zone		
Type of firing mode	A	B	C	A	B	C
Zero Cross	Yes	No	Yes	No	Yes	Yes
Zero Cross Burst	Yes	No	No	No	Yes	No

8.1.6 Low Output

The controller is at 100% output and the Set Point Reference (or command signal) is higher than the Feedback. In other words the controller is being asked to provide a higher output than the load is capable of.

*** WARNING ALARM *
LOW OUTPUT**

8.2 Inhibit Alarms

During an inhibit alarm the STATUS LED will be RED. The display will indicate the alarm that is present. The Status LED will also be red.

Reason: The controller is not registering any line voltage. This could mean the line voltage is too low or not present. The Inhibit alarms can be mapped to Relay 1 and/or 2. This is done through the FUSION Control Panel Software. See the Installation & Maintenance Manual for more details.

8.2.1 AC Line Sync PLL

The line voltage is not present or too low for the controller to operate.

*** INHIBIT ALARM *
AC LINE SYNC PLL**

8.2.2 Current Trip

The controller has exceeded the current trip setting.

This feature will shut the controller down and display an alarm. To get the controller operating once again, a few different methods will remove the current trip alarm. Only one of the following must be done:

1. With hardware: The Run/Reset jumper on P1 (pins 7 & 9). This depends on the run logic selected (Open for Run / Closed for Run). The default is Closed for Run. For this case the Run/Reset jumper has to be opened than closed again.
2. With software: Un-check and check the zone digital "Enable" button. This will be the preferred method when multiple zones are present and only one zone exhibited a Current trip.

*** INHIBIT ALARM *
CURRENT TRIP**

8.2.3 Line Loss

An AC line connection has been lost.

*** INHIBIT ALARM *
LINE LOSS**

8.2.4 Heat Sink Temp

A heat sink has exceeded the temperature rating for the SCR. Check the display to find which zone has triggered the alarm. Check for obstructions preventing the fans from operating correctly.

*** INHIBIT ALARM *
HEAT SINK TEM P**

8.2.5 Fuse Blown

An open fuse is detected. Replace the fuse that has opened. The board will need to be removed. When removing the board make sure all power (line and universal input) is OFF. Replace fuse only with the same current rating. See Fusing section in the Installation and Maintenance manual for correct size and type of fuse. Follow the step-by-step directions in Appendix C of the Installation and Maintenance manual.

8.2.6 Other Non-Typical Alarms

“SRAM ERROR, ROM ERROR, WATCHDOG TIMEOUT, MODULE EEPROM”

These types of errors are uncommon but may occur under specific conditions. Turn off the universal input power and reapply it. If any of these warnings continue to appear, contact factory.

8.3 Heatsink Warning/Inhibit Alarm Temperatures

There is one thermistor for each heatsink. Zone 1 and 2 use the same thermistor, Zone 3 and 4 use the same thermistor. In a three phase controller it is expected that the thermistor on Zone 1 and 2 operates at a higher temperature than the thermistor on Zone 3. When there is an alarm, the display will notify which heatsink(s) are getting to a critical level.

Check the display to find which zone has triggered the alarm, then check for obstructions preventing the fans from operating correctly.

Warning (°C)	Inhibit (°C)
95	100

Once the controller heatsink temperature falls below the critical level, the controller needs to be reset in order to continue to operate. Only one of the following must be done.

1. With hardware: The Run/Reset jumper on P1 (pins 7 & 9). This depends on the run logic selected (Open for Run / Closed for Run). The default is Closed for Run. For this case the Run/Reset jumper has to be opened than closed again.
2. With software: Un-check and check the zone digital “Enable” button. This will be the preferred method when multiple zones are present and only one zone exhibited a Current trip.

8.3.1 Hero Mode

When Hero Mode is enabled, the controller will continue running in the event of an over-temp condition, and the display and indicator LEDs will indicate a warning alarm instead of an inhibit alarm. Please note that enabling this setting voids controller warranty in the event of an over-temperature condition.

For more information about using this feature, consult the FUSION Control Panel software manual.

APPENDIX A - SPECIFICATIONS

Line Power	
Line Voltage (auto ranging)	24 - 600 Vac (Nominal) +10% / -15% lower voltages available for special orders
Line Frequency (auto ranging)	45 - 65 Hz
Frame Current Ratings I Continuous RMS for AC	10, 25, 50, 80, 100, 125, 160
Minimum Hold/Latch Current	1 A RMS
SCR Rating (PIV)	1600 V peak forward & reverse
SCR Protection DV/DT	200 Volt / μ Sec dv/dt protection 1400 V MOV peak voltage protection
SCR Surge Current	Peak 1 cycle surge current is: 10 - 80 Amp rating - 1,750 A 100 - 160 Amp rating - 5,000 A
SCR I ² T Ratings	10 - 80 Amp rating - 15,000 A ² S 100 - 160 Amp rating - 125,000 A ² S
Fusing	Internal compliant with UL, CE or Local Authority
Thermal	Integrated heat sink thermal sensor
Current Limit	20% – 105% of continuous rating of Frame Amp Rating. Factory set to 105%
Current Trip	50% - 450% of continuous rating Factory set to 175% for phase angle Factory set to 350% for zero cross
Power Dissipation	1.3 Watt per amp of load current per phase
Wire Temperature Rating	75°C or higher

Universal Input Power	
Universal Input Power / Operate Internal Control	100 - 240 Vac 50/60 Hz
Power Consumption (max)	1.5 A / 240 V / 360 W

Reliability	
Mean Time Between Failure (MTBF)	Designed for 50,000 Hours

Enclosure Protective Rating	
International	IP 20
Removable Display	IP 65, UL Type 1 & 12

Environmental	
Surrounding Air Operating Temperature	32°F [0°C] - 122°F [50°C] No derating up to 122°F [50°C] at rated current
Humidity	20% to 90% RH Non-Condensing
Rated Operating Altitude	Up to 6000 ft [1750m] at rated current
Contaminates	ROHS Compliant, CE Pollution Degree 2
Storage Temperature	- 4 to 176°F [- 20 to 80°C]

Isolation	
Signal to Line/Load	3750 Vac minimum
Line/Load to Ground	2500 Vac minimum
Signal to Ground	1500 Vac minimum
Line to Load	1400 Vac minimum
Network	1500 Vac minimum
USB	2500 Vac minimum
Signal to Processor	1500 Vac minimum
Remote Display	2500 Vac minimum

Short Circuit Current Rating

All controllers have a 100 KA short circuit current rating when installed in an enclosure, minimum 150% volume of controller size, with at least 2 latches in place.

Cooling	
10 - 25 Amp 1 Zone Single Phase 50 Amp	Natural Convection
50 - 125 Amp	Forced Air with 1 Fan Per Zone (PN 3100KL-05W-B60)
160 Amp	Forced Air with 2 Fans Per Zone (PN 3100KL-05W-B60) Forced Air across fuses with 1 Fan (PN2406KL-05W-B50)

APPENDIX B: MODEL NUMBER IDENTIFICATION

CF - - - - - -

Type of Controller _____

- ZC - Zero Cross
- PA - Phase Angle
- DC - Direct Current

Number of Legs of Control _____

- 1 - 1 Leg
- 2 - 2 Leg (ZC only)
- 3 - 3 Leg

Module Amperage Selections _____

	Single Phase						Three Phase			
	# of Zones	1 Zone	1 Zone	2 Zones	2 Zones	3 Zones	4 Zones	1 Zone 2 Leg	1 Zone 2 Leg	1 Zone 3 Leg
Lines Fused	L1	L1, L2	L1, L2	L1, L2, L3, L4	L1, L2, L3	L1, L2, L3, L4	L1, L2, L3, L4	L1, L2	L1, L2, L3	L1, L2, L3
Current Size	10 Amps	1000	1F00	1100	1F1F	1110	1111	1100	1F10	1110
	25 Amps	2000	2F00	2200	2F2F	2220	2222	2200	2F20	2220
	50 Amps	3000	3F00	3300	3F3F	3330	3333	3300	3F30	3330
	80 Amps	4000	4F00	4400	4F4F	4440	4444	4400	4F40	4440
	100 Amps	5000	5F00	5500	5F5F	5550	5555	5500	5F50	5550
	125 Amps	6000	6F00	6600	6F6F	6660	6666	6600	6F60	6660
	160 Amps	7000	7F00	7700	7F7F	7770	7777	7700	7F70	7770

NOTE: F = Pass-Through Fuse

Multi-Zone Note: When combining current sizes, the first two and last two numbers must be identical. (Examples: 3311, 6655) Higher numbers precede lower numbers.

Factory Industrial Communications* _____

- 0 - None
- E - Modbus TCP (Ethernet)
- N - ProfiNet
- D - DeviceNet
- S - Modbus RTU (RS-485)
- I - Ethernet/IP

*This is in addition to USB, which comes standard on all controllers.

Configuration Data (supplied by Control Concepts, Inc.) _____

Includes configuration data such as load configurations, firing modes, feedback, limits, setpoints, ramp rates, etc.

- 0000 - Standard
- 0001 - 3 Phase Controller with a Inside Delta Load
- 0002 - 3 Phase Controller with a 4 Wire Wye Load
- XXXX - Custom configuration data such as load configurations, firing modes, feedback, limits, setpoints ramp rates, etc., assigned by factory.

Option Card _____

- 0000 - No option card
- 1000 - Auxiliary I/O expansion card [Details found in Installation & Maintenance Manual]

Model Number	Controller Description
CF - PA - 1 - 7000 - 0 - 0000 - 1000	Single Phase, Phase Angle, 160 Amps, Aux I/O Card
CF - PA - 1 - 3330 - E - 0000 - 0000	(3x) Single Phase, Phase Angle, 50 Amps, Modbus TCP
CF - PA - 1 - 7F5F - 0 - 0000 - 0000	(2x) Single Phase, Phase Angle, 160 Amps with Pass-Through Fusing, 100 Amps with Pass-Through Fusing

Custom configurations are available. Contact factory with special requirements and for availability.

This may require a "-SP" to be appended to the model number which would be supplied by Control Concepts, Inc.

APPENDIX C: QUICK START GUIDE

1. Install the controller in desired location with appropriate keep out areas (see Installation & Maintenance Manual for more details).
2. Make all necessary connections.
 - a. Line
 - b. Load
 - c. Ref (single phase, three phase two leg and three phase three leg 4 wire wye controllers only)
 - d. Ground
 - e. Connect the Universal Input Power (100-240 Vac / 50 - 60 Hz)
3. Make communication connections.
 - a. P1 - Command Connector
 - b. P2 - Relay Connector (Optional)
 - c. P3 - Auxiliary I/O Connector (Optional)
4. Apply Power
 - a. Universal Input Power (100 - 240 Vac / 50 - 60 Hz)
 - b. Line (24 - 600 Vac)
5. Place the controller in Run mode via pin 9 as shown in the Command Connectors section.
6. Check Indicator Status LEDs and Display.
 - a. INPUT PWR - green when control power present
 - b. LINE - green when line power present
 - c. STATUS - green when operating
 - d. Display - Alarms will display if present and status LED will be red or flashing orange
7. Apply command signal to adjust setpoint / output



Warning: Disconnect all high voltage before attempting to wire. Wire in accordance to local codes.

If alarms are present, check connections and controller settings. Otherwise see Trouble Shooting section of this manual.